

# 564

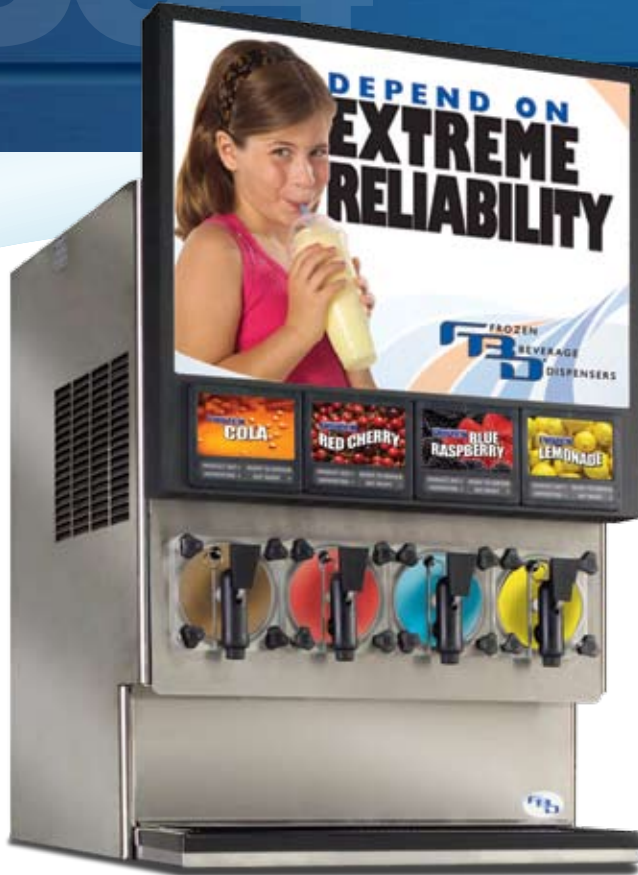

**4-Barrel Dispenser**  
 (Shown with standard door. Customized solutions available.)

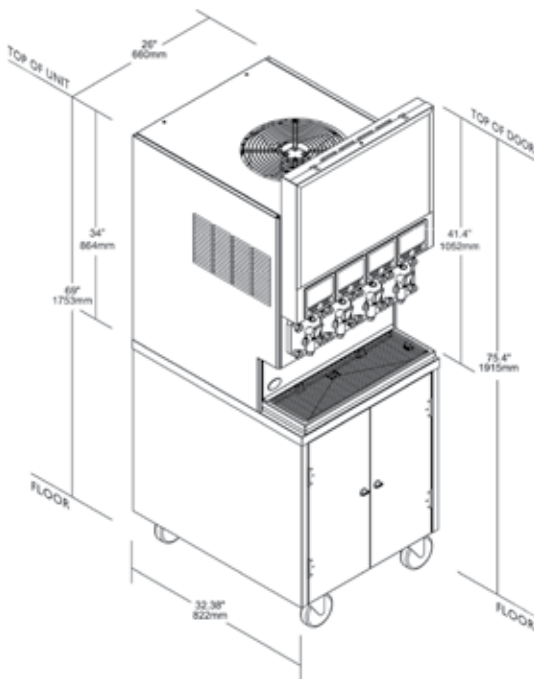

## 564 SPECIFICATIONS

### DIMENSIONS

Countertop unit  
 Width: 26 in (660mm)  
 Depth: 32.38 in (822 mm)  
 Height: 41.4 in (1052 mm)  
 (with merchandiser door)

Unit on base cart  
 Height: 75.4 in (1915 mm)  
 (with merchandiser door)

### ELECTRICAL REQUIREMENTS

215 to 245VAC, single phase; 3 wire, 30 amp;  
 uses NEMA # L-630R receptacle  
 Refrigeration unit:  
 21,000 BTU/Hr, R-404A (50Hz)  
 19,000 BTU/Hr, R-404A (60Hz)

### SPACE REQUIREMENTS

Sides or back: 2 in (51 mm) minimum  
 Top: 12 in (305 mm)

### WEIGHT

Operating unit: 460 lb (208.7 kg)  
 Base cabinet: 80 lb (36.3 kg)

### SYRUP CONNECTION

Bag-In-Box (BIB)

### MOTORS

Beater: (4) 1/6 HP  
 Fan: (1) 1/12 HP

### WATER REQUIREMENTS

Fresh water, minimum 3/8" supply

### OPTIONAL ACCESSORIES

- Base cabinet w/casters (Part # 12-2899-0001)
- Leg kit (set of four) (Part # 12-2533-0001)
- Painted or stainless steel side panels
- Water-cooled unit (as shown)
- Various door options (see spec sheet)
- Remote condenser (see spec sheet)



FBD strives for continuous improvements and engineering innovations.  
 Equipment design and/or specifications may change without notice.